



CHO KEGELSTIRNRADGETRIEBE



CHO Kegelstirradgetriebe wurden austauschbar zur Schneckengetriebebaureihe CH konzipiert, werden dort eingesetzt wo eine hohe Effizienz gefordert wird, vor allem bei hohen Untersetzungen. Sie sind austauschbar und garantieren im Betrieb eine niedrige Gehäusetemperatur. Die Motorwellenverbindung erfolgt über eine Kupplung, verwendbar mit Standardmotoren, Bremsmotoren und explosionsgeschützte Motoren. Diese Getriebe finden Anwendung, wo Energieeinsparung gefordert wird und auch bei Umrichter betriebene Motoren

LEISTUNGSMERKMALE

- Hoher Wirkungsgrad
- Geräuscharm
- Niedrige Betriebstemperatur
- Universale Montage
- Aluminiumgehäuse, lackiert in RAL 9022

CHO Getriebe werden in 4 Größen gefertigt.
Leistungsbereich von 0.12 - 4 KW
Unterstützungen von 7,5 bis 300
Drehmomente, max 130 bis 500 Nm.



LEISTUNG P

$$P_1 \cdot \eta = P_2$$

P_1 = Antriebsleistung

P_2 = Abtriebsleistung

η = Getriebewirkungsgrad

ABTRIEBSDREHZAHL n

n_1 = Antriebsdrehzahl

n_2 = Abtriebsdrehzahl

Eine Antriebsdrehzahl ≤ 1400 rpm wird empfohlen um die Arbeitsbedingungen zu optimieren und die und die Lebensdauer zu erhöhen.

Höhere Drehzahlen werden im Anschluss an die folgende Tabelle erlaubt..

n. DREZAHL	LEISTUNG
1400	Kw
2000	Kw * 1,35
2800	Kw * 1,8

UNTERSETZUNG i

$$i = \frac{n_1}{n_2}$$

90

DREHMOMENT M

$$M_2 = \frac{9550 \cdot P_1 \cdot \eta}{n_2} \text{ [Nm]}$$

$$M_2 \geq M_{2n} \cdot f_s \text{ [Nm]}$$

M_2 = Abtriebsmoment

M_{2n} = Ausgangsnennndrehmoment

P_1 = Antriebsleistung

η = Getriebewirkungsgrad

f_s = Betriebsfaktor



RADIALLAST F_R

Die Radiallast ist proportional zum angeforderten Drehmoment und umgekehrt proportional zum Übertragungselement Durchmesser nach dieser Formel.

$$F_R = \frac{2000 \cdot T \cdot T.e.f.}{D} \left[N \right]$$

F_R = Radiallast
 T = Nm (Torque)
 $T.e.f.$ = Maschinenfaktor
 $T.e.f.$ = 1,15 Getriebe
 = 1,4 Kettenrad
 = 1,75 V-Riemenscheibe
 = 2,5 Flachriemenscheibe
 D = Durchmesser der Übertragungselement

Wirkt die Radiallast nicht auf Wellenmitte, ist es notwendig, die folgende Formel anzuwenden

$$F_{Rx} \leq \frac{F_R \cdot a}{(b+x)} \left[N \right]$$

F_R = Radiallast auf Wellenmitte
 a, b, x = Siehe Tabelle



ABTRIEBSWELLE RADIALKRÄFTE und Axialbelastung F_R, F_A

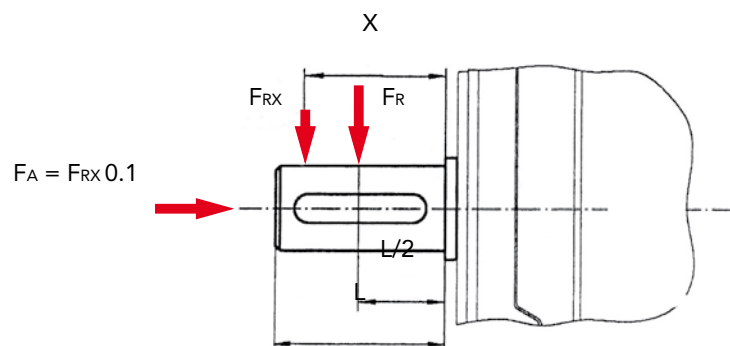

	CHO 52	CHO 53	CHO 62	CHO 63	CHO 72	CHO 73	CHO 82	CHO 83
a	104	104	128	128	135	135	148.5	148.5
b	78	70	98	98	105	105	118.5	118.5



SCHMIERMITTELSORTEN

		ISO	SHELL	MOBIL	BP	Schmiermittelsorte
CHO	standard -10 +40	VG 220	Shell Omala 220	Mobilgear 630	BP Energol GR-XP 220	Mineralöl
	-20 +25	VG 150 VG 100	Shell Omala 100	Mobilgear 627	BP Energol GR-XP 100	
	-30 +10	VG 68-46 VG 32	Shell Tellus T 32	Mobil D.T.E. 13M		
	-40 -20	VG 22 VG 15	Shell Tellus T 15	Mobil D.T.E. 11M	BP Energol HLP-HM 15	
	-40 +80	VG 220	Shell Omala HD 150	Mobil SHC 630		Syntetiköl
	-40 +40	VG 150		Mobil SHC 629		
	-40 +10	VG 32		Mobil SHC 624		

ÖLFÜLLMENGE IN LITER

Die angegebenen Füllmengen werden empfohlen. Die genauen Werte sind Abhängig von der Anzahl der Stufen und das Übersetzungsverhältnis. Die folgenden Tabellen zeigen Richtwerte der Schmierstoff-Füllmengen in Bezug auf die Montageposition (B3, B6, B7 ...)

92

size	Ölfüllmenge in Liter					
	B3	B6	B7	B8	V5	V6
CHO 52	0.22	0.20	0.13	0.15	0.25	0.14
CHO 53	0.07	0.04	0.04	0.05	0.08	0.09
CHO 62	0.38	0.35	0.25	0.26	0.44	0.25
CHO 63	0.07	0.04	0.04	0.05	0.08	0.09
CHO 72	0.66	0.60	0.45	0.48	0.78	0.47
CHO 73	0.13	0.09	0.09	0.09	0.15	0.17
CHO 82	1.15	0.93	0.70	0.74	1.25	0.75
CHO 83	0.13	0.09	0.09	0.09	0.15	0.17

CHO Getriebe werden komplett mit Mineralöl geliefert (Ölfüllmenge gilt für Montage in Position B3 . Die Vorstufe (dritte Stufe) wird mit synthetischem Öl geschmiert und ist komplett geschlossen



INSTANDHALTUNG

- 1 Bei den Getrieben sollte der erste Ölwechsel nach ca. 300 Stunde (Laufzeit) erfolgen. Mischen Sie niemals das synthetische Öl und Mineralöl zusammen.
- 2 Nach 3000 h Laufzeit, mindestens alle 6 Monate, haben Sie das Öl und Ölstand, sowie die Dichtungen visuell auf Leckage zu überprüfen. Für Getriebe mit IEC-Eingang-Getriebe sollte die Kupplung geprüft werden ,bei Bedarf Elastomer ersetzen.
- 3 In Abhängigkeit von den Betriebsbedingungen ist spätestens alle 3 Jahre eine Inspektion erforderlich. Dann muss das Mineralöl und das Lagerfett gewechselt werden.
- 4 In Abhängigkeit von den Betriebsbedingungen , die Wellendichtringe wechseln.
- 5 Stellen Sie sicher, dass die Motorkupplung immer geschmiert ist um Verschleißrisiken zu vermeiden.



BEZEICHNUNG

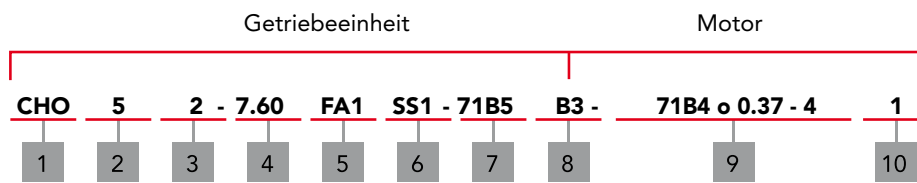

No	Comments
1	Code für Getriebeeinheit CHO
2	Getriebegröße 5-6-7-8
3	2 gleich zweistufig 3 gleich dreistufig
4	Getriebeübersetzung i=
5	1) keine Markierung bedeutet ohne Abtriebsflansch 2) FA, FB, FC, FD, FE (1/2) : Abtriebsflansch und Position
6	1) keine Markierung bedeutet Abtriebshohlwelle 2) SS(1/2) : einseitige Abtriebswelle und Position 3) DS : beidseitige Abtriebswelle
7	Motoreingangsfansch (63B5, 71B5 ...)
8	Einbaulage
9	1) keine Markierung ohne Motor 2) Motorgröße und Polzahl
10	Einbaulage des Klemmkastens

Bestellbeispiel

CHO 82 15.09 - FA1 - 71B5 - 71C4/3



UNTERSTZUNGEN UND IEC MOTOR ADAPTER

CHO 52/53		n ₁ = 1400 r/min						130Nm			
i nominal	i actual	n ₂ [r/min]	M _{2n} [Nm]	P1=Kw	M1	F.S.	F _{r2} [N]	63B5	71B5 71B14	80B5 80B14	90B5 90B14

3 stages

CHO 53

300	291.79	4.8	110	0.12	183	0.60	4100				
250	244.29	5.8	130	0.12	173	0.75	4100				
200	200.44	7.0	130	0.12	137	0.95	4100				
150	146.67	9.6	130	0.18	151	0.86	4000				
125	120.34	12	130	0.18	124	1.05	3770				
100	101.04	14	130	0.25	144	0.90	3560				
75	74.62	19	130	0.37	159	0.82	3220				

2 stages

CHO 52

60	58.36	24	110	0.37	133	0.83	2960				
50	48.86	29	130	0.37	110	1.18	2790				
40	40.09	35	130	0.55	130	1.00	2610				
30	29.33	48	130	0.75	137	0.95	2350				
25	24.07	59	130	0.75	110	1.18	2200				
20	20.21	70	130	1.10	130	1.00	2080				
15	14.92	94	130	1.50	137	0.95	1880				
12.5	12.47	113	120	1.50	114	1.05	1770				
10	10.47	134	110	1.50	96	1.15	1670				
7.5	7.73	182	100	1.50	70	1.42	1510				

94

CHO 62/63		n ₁ = 1400 r/min						200Nm			
i nominal	i actual	n ₂ [r/min]	M _{2n} [Nm]	P1=Kw	M1	F.S.	F _{r2} [N]	63B5	71B5 71B14	80B5 80B14	90B5 90B14

3 stages

CHO 63

300	302.50	4.7	170	0.12	210	0.81	4800				
250	243.57	5.8	200	0.18	250	0.80	4800				
200	196.43	7.2	200	0.25	286	0.70	4800				
150	151.56	9.3	200	0.25	222	0.90	4650				
125	122.22	12	200	0.37	263	0.76	4330				
100	101.27	14	200	0.37	215	0.93	4070				
75	73.33	20	200	0.55	233	0.86	3650				

2 stages

CHO 62

60	60.50	24	170	0.55	205	0.83	3430				
50	48.71	29	200	0.75	217	0.92	3190				
40	39.29	36	200	0.75	180	1.11	2970				
30	30.31	47	200	1.10	200	1.00	2720				
25	24.44	58	200	1.50	217	0.92	2530				
20	20.25	70	200	1.50	180	1.11	2380				
15	14.67	96	200	1.50	135	1.48	2130				
12.5	12.67	111	180	1.50	118	1.53	2030				
10	10.50	134	170	1.50	94	1.80	1910				
7.5	7.60	185	160	1.50	68	2.35	1710				

2D - und 3D-Zeichnungen auf der Website : www.chiaravalli.com
Menge, Verfügbarkeit und Preise bei ZM Antriebstechnik anfragen



UNTERSETZUNGEN UND IEC MOTOR ADAPTER

CHO 72/73		n ₁ = 1400 r/min							350Nm				
i nominal	i actual	n ₂ [r/min]	M _{2n} [Nm]	P1=Kw	M1	F.S.	F _{r2} [N]	63B5	71B5	80B5 80B14	90B5 90B14	100B5 100B14	112B5 112B14

CHO 73

3 stages

300	297.21	4.8	350	0.25	432	0.81	6500						
250	240.89	5.9	350	0.25	350	1.00	6500						
200	200.66	7.0	350	0.25	291	1.19	6500						
150	151.20	9.3	350	0.37	324	1.08	6500						
125	125.95	12	350	0.55	398	0.88	5980						
100	99.22	15	350	0.55	314	1.11	5520						
75	75.45	19	350	0.75	318	1.10	5040						

CHO 72

2 stages

60	59.44	24	350	1.10	394	0.88	4660						
50	48.18	30	350	1.10	324	1.08	4340						
40	40.13	35	350	1.50	350	1.00	4080						
30	30.24	47	350	1.50	269	1.30	3720						
25	25.19	56	350	2.20	318	1.10	3500						
20	19.84	71	350	2.20	269	1.30	3230						
15	15.09	93	350	3.00	269	1.30	2950						
12.5	12.49	113	330	4.00	311	1.06	2770						
10	9.84	143	320	4.00	244	1.31	2550						
7.5	7.48	188	310	4.00	186	1.67	2330						

CHO 82/83		n ₁ = 1400 r/min							500Nm				
i nominal	i actual	n ₂ [r/min]	M _{2n} [Nm]	P1=Kw	M1	F.S.	F _{r2} [N]	63B5	71B5	80B5 80B14	90B5 90B14	100B5 100B14	112B5 112B14

CHO 83

3 stages

300	295.18	4.8	460	0.25	425	1.08	8300						
250	240.89	5.9	500	0.37	500	1.00	8300						
200	200.66	7.0	500	0.37	433	1.15	8300						
150	151.20	9.3	500	0.55	481	1.04	8050						
125	125.95	12	500	0.75	532	0.94	7580						
100	99.22	15	500	0.75	417	1.20	7000						
75	75.45	19	500	1.10	481	1.04	6390						

CHO 82

2 stages

60	59.04	24	460	1.50	489	0.94	5890						
50	48.17	30	500	1.50	435	1.15	5500						
40	40.13	35	500	2.20	543	0.92	5170						
30	30.24	47	500	2.20	407	1.23	4710						
25	25.19	56	500	3.00	450	1.11	4430						
20	19.84	71	500	4.00	500	1.00	4090						
15	15.09	93	500	4.00	373	1.34	3730						
12.5	12.49	113	480	4.00	310	1.55	3510						
10	9.84	143	460	4.00	243	1.89	3240						
7.5	7.48	188	440	4.00	186	2.37	2950						



GETRIEBEAUSWAHLTABELLEN

P_{1n} [Kw]	n_2 [r/min]	M_{2n} [Nm]	i nominal	i aktuell	F_{r2} [N]	f_s				
0.12	5.7	184	250	244.29	4100	0.7	CHO53	63B5	63A4	
	7.0	151	200	200.44	4100	0.9				
	9.5	110	150	146.67	4000	1.2				
	11.6	91	125	120.34	3770	1.4				
	13.9	76	100	101.04	3560	1.7				
	18.8	56	75	74.62	3220	2.3				
	24.0	45	60	58.36	2960	2.4	CHO52	63B5	63A4	
	28.7	38	50	48.86	2790	3.5				
	35	31	40	40.09	2610	4.2				
	48	23	30	29.33	2350	5.8				
	58	18.5	25	24.07	2200	7.0				
	69	15.6	20	20.21	2080	8.4				
	94	11.5	15	14.92	1880	11.3				
112	9.6	12.5	12.47	1770	13.5					
134	8.1	10	10.47	1670	16.1					
181	5.9	7.5	7.73	1510	16.8					
	5.7	183	250	243.57	4800	1.1	CHO63	63B5	63A4	
	7.1	148	200	196.43	4800	1.4				
	9.2	114	150	151.56	4650	1.8				
	11.5	92	125	122.22	4330	2.2				
	13.8	76	100	101.27	4070	2.6				
	19.1	55	75	73.33	3650	2.9				
	4.7	224	300	297.21	6500	1.6	CHO73	63B5	63A4	
	5.8	181	250	240.89	6500	1.9				
	7.0	151	200	200.66	6500	2.3				
	4.7	222	300	295.18	8300	2.1	CHO83	63B5	63A4	
	5.8	181	250	240.89	8300	2.8				
	0.18	48	34	60	58.36	2350	3.3	CHO52	63B5	63A2
		57	28	50	48.86	2220	4.6			
70		23	40	40.09	2070	5.6				
95		16.9	30	29.33	1870	7.7				
116		13.9	25	24.07	1750	9.4				
11.6		136	125	120.34	3770	1.0	CHO53	63B5	63B4	
13.9		114	100	101.04	3560	1.1				
18.8		84	75	74.62	3220	1.5				
24		67	60	58.36	2960	1.6	CHO52	63B5	63B4	
28.7		56	50	48.86	2790	2.3				
35		46	40	40.09	2610	2.8				
48		34	30	29.33	2350	3.8				
58		28	25	24.07	2200	4.7				
69	23	20	20.21	2080	5.6					
94	17.2	15	14.92	1880	7.5					
112	14.4	12.5	12.47	1770	9.0					
134	12.1	10	10.47	1670	10.8					
181	8.9	7.5	7.73	1510	11.2					



GETRIEBEAUSWAHLTABELLEN

P_{1n}	n_2	M_{2n}	i	i	F_{r2}	f_s			
$[Kw]$	$[r/m]_n$	$[Nm]$	nominal	aktuell	$[N]$				
0.18	15.4	105	60	58.36	3430	1.0	CHO52	71B5/B14	71A6
	18.4	88	50	48.86	3240	1.5			
	22.4	72	40	40.09	3030	1.8			
	31	53	30	29.33	2730	2.5			
	37	43	25	24.07	2550	3.0			
	7.1	222	200	196.43	4800	0.9	CHO63	63B5	63B4
	9.2	171	150	151.56	4650	1.2			
	11.5	138	125	122.22	4330	1.4			
	13.8	114	100	101.27	4070	1.7			
	19.1	83	75	73.33	3650	1.9			
	23.1	70	60	60.50	3430	2.4	CHO62	63B5	63B4
	28.7	56	50	48.71	3190	3.6			
	7.4	215	125	122.22	4800	0.9	CHO63	71B5/B14	71A6
	8.9	178	100	101.27	4720	1.1			
	12.3	129	75	73.33	4230	1.2			
	14.9	109	60	60.50	3970	1.6	CHO62	71B5/B14	71A6
	18.5	87	50	48.71	3690	2.3			
	22.9	71	40	38.29	3440	2.8			
	4.7	336	300	297.21	6500	1.0	CHO73	63B5	63B4
	5.8	272	250	240.89	6500	1.3			
	7.0	227	200	200.66	6500	1.5			
	9.3	171	150	151.20	6500	2.0			
	11.1	142	125	125.95	5980	2.5			
	14.1	112	100	99.22	5520	3.1			
	4.5	353	200	200.66	6500	1.0	CHO73	71B5	71A6
	6.0	266	150	151.20	6500	1.3			
	7.1	221	125	125.95	6500	1.6			
	9.1	174	100	99.22	6400	2.0			
	11.9	133	75	75.45	5840	2.6			
	4.7	333	300	295.18	8300	1.4	CHO83	63B5	63B4
	5.8	272	250	240.89	8300	1.8			
	7.0	227	200	200.66	8300	2.2			
	9.3	171	150	151.20	8050	2.9			
	3.7	423	250	240.89	8300	1.2	CHO83	71B5	71A6
	4.5	353	200	200.66	8300	1.4			
	6.0	266	150	151.20	8300	1.9			
	7.1	221	125	125.95	8300	2.3			
	9.1	174	100	99.22	8110	2.9			
0.25	19.1	115	150	146.67	3200	1.1	CHO53	63B5	63B2
	23.3	94	125	120.34	2990	1.4			
	27.7	79	100	101.04	2820	1.6			
	38	59	75	74.62	2550	2.2			
	48	47	60	58.36	2350	2.4	CHO52	63B5	63B2
	57	39	50	48.86	2220	3.3			
	70	32	40	40.09	2070	4.0			



GETRIEBEAUSWAHLTABELLEN

P_{1n} [Kw]	n_2 [r/min]	M_{2n} [Nm]	i nominal	i aktuell	F_{r2} [N]	f_s			
0.25	24	94	60	58.36	2960	1.2	CHO52	71B5/B14	71A4
	28.7	78	50	48.86	2790	1.7			
	35	64	40	40.09	2610	2.0			
	48	47	30	29.33	2350	2.8			
	58	39	25	24.07	2200	3.4			
	69	32	20	20.21	2080	4.0			
	94	24	15	14.92	1880	5.4			
	18.4	122	50	48.86	3240	1.1	CHO52	71B5/B14	71B6
	22.4	100	40	40.09	3030	1.3			
	31	73	30	29.33	2730	1.8			
	37	60	25	24.07	2550	2.2			
	45	50	20	20.21	2410	2.6			
	60	37	15	14.92	2180	3.5			
	72	31	12.5	12.47	2050	4.2			
	86	26	10	10.47	1930	5.0			
	116	19	7.5	7.73	1750	5.2			
	11.5	191	250	243.57	4330	1.0	CHO63	63B5	63B2
	14.3	154	200	196.43	4030	1.3			
	18.5	119	150	151.56	3690	1.7			
	22.9	96	125	122.22	3440	2.1			
	27.6	78	100	101.27	3230	2.5			
	38	58	75	73.33	2900	2.8			
	11.5	192	125	122.22	4330	1.0	CHO63	71B5/B14	71A4
	13.8	159	100	101.27	4070	1.3			
	19.1	115	75	73.33	3650	1.4			
	23.1	97	60	60.50	3430	1.8	CHO62	71B5/B14	71A4
	28.7	78	50	48.71	3190	2.6			
	36	63	40	39.29	2970	3.2			
	46	49	30	30.31	2720	4.1			
	14.9	151	60	60.50	3970	1.1	CHO62	71B5/B14	71B6
	18.5	121	50	48.71	3690	1.6			
	22.9	98	40	39.29	3440	2.0			
	29.7	76	30	30.31	3150	2.6			
	9.4	233	300	297.21	6320	1.5	CHO73	63B5	63B2
	11.6	189	250	240.89	5890	1.9			
	14	157	200	200.66	5540	2.2			
	18.5	119	150	151.20	5040	3.0			
	5.8	378	250	240.89	6500	0.9	CHO73	71B5	71A4
	7.0	315	200	200.66	6500	1.1			
	9.3	237	150	151.20	6500	1.5			
	11.1	198	125	125.95	5980	1.8			
	14.1	156	100	99.22	5520	2.2			
	18.6	118	75	75.45	5040	3.0			
	6	369	150	151.20	6500	0.9	CHO73	71B5	71B6
	7.1	307	125	125.95	6500	1.1			

2D- und 3D-Zeichnungen auf der Website : www.chiaravalli.com
Menge, Verfügbarkeit und Preise bei ZM Antriebstechnik anfragen



GETRIEBEAUSWAHLTABELLEN

P_{1n} [Kw]	n_2 [r/min]	M_{2n} [Nm]	i nominal	i aktuell	F_{r2} [N]	f_s			
0.25	9.1	242	100	99.22	6400	1.4	CHO73	71B5	71B6
	11.9	184	75	75.45	5840	1.9			
	15.1	148	60	59.44	5390	2.4	CHO72	71B5	71B6
	18.7	120	50	48.18	5030	2.9			
	22.4	100	40	40.13	4730	3.5			
	4.7	463	300	295.18	8300	1.0	CHO83	71B5	71A4
	5.8	378	250	240.89	8300	1.3			
	7.0	315	200	200.66	8300	1.6			
	9.3	237	150	151.20	8050	2.1			
	11.1	198	125	125.95	7580	2.5			
	4.5	490	200	200.66	8300	1.0	CHO83	71B5	71B6
	6.0	369	150	151.20	8300	1.4			
	7.1	307	125	125.95	8300	1.6			
	9.1	242	100	99.22	8110	2.1			
11.9	184	75	75.45	7400	2.7				
0.37	23.3	140	125	120.34	2990	0.9	CHO53	71B5/B14	71A2
	27.7	117	100	101.04	2820	1.1			
	38	87	75	74.62	2550	1.5			
	48	69	60	58.36	2350	1.6	CHO52	71B5/B14	71A2
	57	58	50	48.86	2220	2.2			
	70	48	40	40.09	2070	2.7			
	95	35	30	29.33	1870	3.7			
	28.7	116	50	48.86	2790	1.1	CHO52	71B5/B14	71B4
	35	95	40	40.09	2610	1.4			
	48	70	30	29.33	2350	1.6			
	58	57	25	24.07	2200	2.3			
	69	48	20	20.21	2080	2.7			
	94	35	15	14.90	1880	3.7			
	112	30	12.5	12.47	1770	4.4			
	134	25	10	10.47	1670	5.2			
	181	18	7.5	7.73	1510	5.5			
	31	108	30	29.33	2730	1.2	CHO52	80B5/B14	80A6
	37	89	25	24.07	2550	1.5			
	45	75	20	20.21	2410	1.7			
	60	55	15	14.92	2180	2.4			
	72	46	12.5	12.47	2050	2.8			
	86	39	10	10.47	1930	3.4			
	116	29	7.5	7.73	1750	3.5			
	14.3	228	200	196.43	4030	0.9	CHO63	71B5/B14	71A2
	18.5	176	150	151.56	3690	1.1			
	22.9	142	125	122.22	3440	1.4			
27.6	118	100	101.27	3230	1.7				
46	72	60	60.50	2720	2.4	CHO62	71B5/B14	71A2	
57	58	50	48.71	2530	3.5				
71	47	40	39.29	2350	4.3				



GETRIEBEAUSWAHLTABELLEN

P_{1n} [Kw]	n_2 [r/min]	M_{2n} [Nm]	i nominal	i aktuell	F_{r2} [N]	f_s			
0.37	13.8	235	100	101.27	4070	0.9	CHO63	71B5/B14	71B4
	19.1	170	75	73.33	3650	0.9			
	23.1	144	60	60.50	3430	1.2	CHO62	71B5/B14	71B4
	28.7	116	50	48.71	3190	1.7			
	36	93	40	39.29	2970	2.1			
	46	72	30	30.31	2720	2.8			
	57	58	25	24.44	2530	3.4			
	69	48	20	20.25	2380	4.2			
	18.5	180	50	48.71	3690	1.1	CHO62	80B5/B14	80A6
	22.9	145	40	39.29	3440	1.4			
	29.7	112	30	30.31	3150	1.8			
	37	90	25	24.44	2930	2.2			
	44	75	20	20.25	2760	2.7			
	61	54	15	14.67	2470	3.5			
	71	47	12.5	12.67	2360	3.5			
	86	39	10	10.50	2210	3.5			
	118	28	7.5	7.60	1990	3.6			
	9.4	345	300	297.21	6320	1.0	CHO73	71B5	71A2
	11.6	280	250	240.89	5890	1.3			
	14	233	200	200.66	5540	1.5			
	18.5	176	150	151.20	5040	2.0			
	9.3	351	150	151.20	6500	1.0	CHO73	71B5	71B4
	11.1	292	125	125.95	5980	1.2			
	14.1	230	100	99.22	5520	1.5			
	18.6	175	75	75.45	5040	2.0			
	23.6	141	60	59.44	4660	2.5	CHO72	71B5	71B4
	29.1	114	50	48.18	4340	3.1			
	9.1	358	100	99.22	6400	1.0	CHO73	80B5/B14	80A6
	11.9	273	75	75.45	5840	1.3			
	15.1	219	60	59.44	5390	1.6	CHO72	80B5/B14	80A6
	18.7	178	50	48.18	5030	2.0			
	22.4	148	40	40.13	4730	2.4			
	29.8	112	30	30.24	4310	3.1			
	9.5	343	300	295.18	7990	1.3	CHO83	71B5	71A2
	11.6	280	250	240.89	7470	1.8			
	14.0	233	200	200.66	7030	2.1			
	18.5	176	150	151.20	6390	2.8			
	22.2	146	125	125.95	6010	3.4			
	5.8	559	250	240.89	8300	0.9	CHO83	71B5	71B4
	7.0	466	200	200.66	8300	1.1			
	9.3	351	150	151.20	8050	1.4			
	11.1	292	125	125.95	7580	1.7			
	14.1	230	100	99.22	7000	2.2			
	18.6	175	75	75.45	6390	2.9			
	22.4	145	60	62.43	6000	3.1			

2 D - und 3D-Zeichnungen auf der Website : www.chiaravalli.com
Menge, Verfügbarkeit und Preise bei ZM Antriebstechnik anfragen



GETRIEBEAUSWAHLTABELLEN

P_{1n} [Kw]	n_2 [r/min]	M_{2n} [Nm]	i nominal	i aktuell	F_{r2} [N]	f_s			
0.37	28.5	114	50	49.18	5540	3.1	CHO83	71B5	71B4
	6.0	546	150	151.20	8300	0.9	CHO83	80B5/B14	80A6
	7.1	455	125	125.95	8300	1.1			
	9.1	358	100	99.22	8110	1.4			
	11.9	273	75	75.45	7400	1.8			
	15.2	218	60	59.04	6820	2.1	CHO82	80B5/B14	80A6
	18.7	178	50	48.18	6370	2.8			
0.55	70	71	40	40.09	2070	1.8	CHO52	71B5/B14	71B2
	95	52	30	29.33	1870	2.5			
	116	42	25	24.07	1750	3.1			
	139	36	20	20.21	1650	3.6			
	35	141	40	40.09	2610	0.9	CHO52	80B5/B14	80A4
	48	103	30	29.33	2350	1.3			
	58	85	25	24.07	2200	1.5			
	69	71	20	20.21	2080	1.8			
	94	53	15	14.92	1880	2.5			
	112	44	12.5	12.47	1770	3.0			
	134	37	10	10.47	1670	3.5			
	181	27	7.5	7.73	1510	3.7			
	22.9	211	125	122.22	3440	0.9	CHO63	71B5/B14	71B2
	27.6	175	100	101.27	3230	1.1			
	38	127	75	73.33	2900	1.3			
	46	107	60	60.50	2720	1.6	CHO62	71B5/B14	71B2
	57	86	50	48.71	2530	2.3			
	71	69	40	39.29	2350	2.9			
	92	53	30	30.31	2160	3.7			
	28.7	172	50	48.71	3190	1.2	CHO62	80B5/B14	80A4
	36	139	40	39.29	2970	1.4			
	46	107	30	30.31	2720	1.9			
	57	86	25	24.44	2530	2.3			
	69	71	20	20.25	2380	2.8			
	95	52	15	14.67	2130	3.7			
	110	45	12.5	12.67	2030	3.7			
	133	37	10	10.50	1910	3.6			
	184	27	7.5	7.60	1710	3.7			
	22.9	216	40	39.29	3440	0.9	CHO62	80B5/B14	80B6
	29.7	166	30	30.31	3150	1.2			
	37	134	25	24.44	2930	1.5			
	44	111	20	20.25	2760	1.8			
61	80	15	14.67	2470	2.4				
71	70	12.5	12.67	2360	2.4				
86	58	10	10.50	2210	2.3				
118	42	7.5	7.60	1990	2.4				
14	346	200	200.66	5540	1.0	CHO73	71B5	71B2	
18.5	261	150	151.20	5040	1.3				



GETRIEBEAUSWAHLTABELLEN

P_{1n} [Kw]	n_2 [r/min]	M_{2n} [Nm]	i nominal	i aktuell	F_{r2} [N]	f_s			
0.55	22.2	217	125	125.95	4750	1.6	CHO73	71B5	71B2
	28.2	171	100	99.22	4380	2.0			
	37	130	75	75.45	4000	2.7			
	45	108	60	62.43	3750	3.2			
	57	85	50	49.18	3470	4.1			
	14.1	342	100	99.22	5520	1.0	CHO73	80B5/B14	80A4
	18.6	260	75	75.45	5040	1.3			
	23.6	210	60	59.44	4660	1.7	CHO72	80B5/B14	80A4
	29.1	170	50	48.18	4340	2.1			
	35	142	40	40.13	4080	2.5			
	46	107	30	30.24	3720	3.3			
	15.1	326	60	59.44	5390	1.1	CHO72	80B5/B14	80B6
	18.7	264	50	48.18	5030	1.3			
	22.4	220	40	40.13	4730	1.6			
	29.8	166	30	30.24	4310	2.1			
	9.5	509	300	295.18	7990	0.9	CHO83	71B5	71B2
	11.6	416	250	240.89	7470	1.2			
	14.0	346	200	200.66	7030	1.4			
	18.5	261	150	151.20	6390	1.9			
	22.2	217	125	125.95	6010	2.3			
	9.3	522	150	151.20	8050	1.0	CHO83	80B5/B14	80A4
	11.1	435	125	125.95	7580	1.2			
	14.1	342	100	99.22	7000	1.5			
	18.6	260	75	75.45	6390	1.9			
	23.7	208	60	59.04	5890	2.2	CHO82	80B5/B14	80A4
	29.1	170	50	48.18	5500	2.9			
	9.1	533	100	99.22	8110	0.9	CHO83	80B5/B14	80B6
	11.9	405	75	75.45	7400	1.2			
	15.2	324	60	59.04	6820	1.4	CHO82	80B5/B14	80B6
	18.7	264	50	48.18	6370	1.9			
	22.4	220	40	40.13	6000	2.3			
0.75	57	117	50	48.86	2220	1.1	CHO52	80B5/B14	80A2
	70	96	40	40.09	2070	1.3			
	95	71	30	29.33	1870	1.8			
	116	58	25	24.07	1750	2.2			
	139	49	20	20.21	1650	2.7			
	188	36	15	14.92	1490	3.6			
	48	141	30	29.33	2350	0.9	CHO52	80B5/B14	80B4
	58	116	25	24.07	2200	1.1			
	69	97	20	20.21	2080	1.3			
	94	72	15	14.92	1880	1.8			
	112	60	12.5	12.47	1770	2.2			
	134	50	10	10.47	1670	2.6			
	181	37	7.5	7.73	1510	2.7			

2 D - und 3D-Zeichnungen auf der Website : www.chiaravalli.com
Menge, Verfügbarkeit und Preise bei ZM Antriebstechnik anfragen



GETRIEBEAUSWAHLTABELLEN

P_{1n} [Kw]	n_2 [r/min]	M_{2n} [Nm]	i nominal	i actual	F_{r2} [N]	f_s			
0.75	46	145	60	60.50	2720	1.2	CHO62	80B5/B14	80A2
	57	117	50	48.71	2530	1.7			
	71	94	40	39.29	2350	2.1			
	92	73	30	30.31	2160	2.7			
	115	59	25	24.44	2010	3.4			
	138	49	20	20.25	1890	4.1			
	28.7	234	50	48.71	3190	0.9	CHO62	80B5/B14	80B4
	36	189	40	39.29	2970	1.1			
	46	146	30	30.31	2720	1.4			
	57	118	25	24.44	2530	1.7			
	69	97	20	20.25	2380	2.1			
	95	71	15	14.67	2130	2.8			
	18.5	356	150	151.20	5040	1.0	CHO73	80B5/B14	80A2
	22.2	296	125	125.95	4750	1.2			
	28.2	234	100	99.22	4380	1.5			
	37	178	75	75.45	4000	2.0			
	47	143	60	59.44	3690	2.4	CHO72	80B5/B14	80A2
	58	116	50	48.18	3440	3.0			
	70	96	40	40.13	3240	3.6			
	23.6	286	60	59.44	4660	1.2	CHO72	80B5/B14	80B4
	29.1	232	50	48.18	3440	1.5			
	35	193	40	40.13	4080	1.8			
	46	145	30	30.24	3720	2.4			
	56	121	25	25.19	3500	2.9			
	18.7	360	50	48.18	5030	1.0	CHO72	90B5/B14	90S6
	22.4	300	40	40.13	4730	1.2			
	29.8	226	30	30.24	4310	1.5			
	36	188	25	25.19	4050	1.9			
	45	148	20	19.84	3740	2.4			
	11.6	567	250	240.89	7470	0.9	CHO83	80B5/B14	80A2
	14.0	472	200	200.66	7030	1.1			
	18.5	356	150	151.20	6390	1.4			
	22.2	296	125	125.95	6010	1.7			
	28.2	234	100	99.22	5550	2.1			
	37	178	75	75.45	5070	2.8			
	14.1	467	100	99.22	7000	1.1	CHO83	80B5/B14	80B4
	18.6	355	75	75.45	6390	1.4			
	23.7	284	60	59.04	5890	1.6	CHO82	80B5/B14	80B4
	29.1	232	50	48.18	5500	2.2			
	35	193	40	40.13	5170	2.6			
	15.2	442	60	59.04	6820	1.0	CHO82	90B5/B14	90S6
	18.7	360	50	48.18	6370	1.4			
	22.4	300	40	40.13	6000	1.7			
	29.8	226	30	30.24	5460	2.2			



GETRIEBEAUSWAHLTABELLEN

P_{1n}	n_2	M_{2n}	i	i	F_{r2}	f_s			
[Kw]	[r/min]	[Nm]	nominal	actual	[N]				
1.1	70	141	40	40.09	2070	0.9	CHO52	80B5/B14	80B2
	95	103	30	29.33	1870	1.3			
	116	85	25	24.07	1750	1.5			
	139	71	20	20.21	1650	1.8			
	188	53	15	14.92	1490	2.5			
	225	44	12.5	12.47	1400	3.0			
	267	37	10	10.47	1320	3.5			
	362	27	7.5	7.73	1200	3.7			
	69	143	20	20.21	2080	0.9	CHO52	90B5/B14	90S4
	94	105	15	14.92	1880	1.2			
112	88	12.5	12.47	1770	1.5				
134	74	10	10.47	1670	1.8				
181	55	7.5	7.73	1510	1.8				
72	137	12.5	12.47	2050	1.0	CHO52	90B5/B14	90L6	
86	115	10	10.47	1930	1.1				
57	172	50	48.71	2530	1.2	CHO62	80B5/B14	80B2	
71	139	40	39.29	2350	1.4				
92	107	30	30.31	2160	1.9				
115	86	25	24.44	2010	2.3				
138	71	20	20.25	1890	2.8				
191	52	15	14.67	1690	3.7				
221	45	12.5	12.67	1610	3.7				
267	37	10	10.50	1510	3.6				
368	27	7.5	7.60	1710	1.9				
46	214	30	30.31	2720	0.9	CHO62	90B5/B14	90S4	
57	172	25	24.44	2530	1.2				
69	143	20	20.25	2380	1.4				
95	103	15	14.67	2130	1.8				
110	89	12.5	12.67	2030	1.8				
133	74	10	10.50	1910	1.8				
184	54	7.5	7.60	1360	3.7				
44	222	20	20.25	2760	0.9	CHO62	90B5/B14	90L6	
61	161	15	14.67	2470	1.2				
71	139	12.5	12.67	2360	1.2				
86	115	10	10.50	2210	1.2				
118	83	7.5	7.60	1990	1.2				
29.1	340	50	48.18	4340	1.0	CHO72	90B5/B14	90S4	
35	283	40	40.13	4080	1.2				
46	213	30	30.24	3720	1.6				
56	178	25	25.19	3500	2.0				
71	140	20	19.84	3230	2.5				
93	106	15	15.09	2950	3.3				
112	88	12.5	12.49	2770	4.0				
29.8	332	30	30.24	4310	1.1	CHO72	90B5/B14	90L6	
36	276	25	25.19	4050	1.3				

2D- und 3D-Zeichnungen auf der Website : www.chiaravalli.com
Menge, Verfügbarkeit und Preise bei ZM Antriebstechnik anfragen



GETRIEBEAUSWAHLTABELLEN

P_{1n} [Kw]	n_2 [r/min]	M_{2n} [Nm]	i nominal	i actual	F_{r2} [N]	f_s			
1.1	45	218	20	19.84	3740	1.6	CHO72	90B5/B14	90L6
	60	166	15	15.09	3410	2.1			
	72	137	12.5	12.49	3210	2.6			
	18.5	522	150	151.20	6390	1.0	CHO83	80B5/B14	80B2
	22.2	435	125	125.95	6010	1.2			
	28.2	342	100	99.22	5550	1.5			
	37	260	75	75.45	5070	1.9			
	47	208	60	59.04	4670	2.2	CHO82	80B5/B14	80B2
	58	170	50	48.18	4360	2.9			
	18.6	521	75	75.45	6390	1.0	CHO83	90B5/B14	90S4
	23.7	416	60	59.04	5890	1.1	CHO82	90B5/B14	90S4
	29.1	340	50	48.18	5500	1.5			
	35	283	40	40.13	5170	1.8			
	46	213	30	30.24	4710	2.3			
	18.7	529	50	48.18	6370	0.9	CHO82	90B5/B14	90L6
	22.4	440	40	40.13	6000	1.1			
	29.8	332	30	30.24	5460	1.5			
	36	276	25	25.19	5130	1.8			
45	218	20	19.84	4740	2.3				
1.5	116	116	25	24.07	1750	1.1	CHO52	90B5/B14	90S2
	139	97	20	20.21	1650	1.3			
	188	72	15	14.92	1490	1.8			
	225	60	12.5	12.47	1400	2.0			
	267	50	10	10.47	1320	2.2			
	362	37	7.5	7.73	1200	2.6			
	94	144	15	14.92	1880	0.9	CHO52	90B5/B14	90L4
	112	120	12.5	12.47	1770	1.6			
	134	101	10	10.47	1670	1.1			
	181	74	7.5	7.73	1510	1.3			
	57	234	50	48.71	2530	0.9	CHO62	90B5/B14	90S2
	71	189	40	39.29	2350	1.1			
	92	146	30	30.31	2160	1.4			
	115	118	25	24.44	2010	1.7			
	138	97	20	20.25	1890	2.0			
	191	71	15	14.67	1690	2.8			
	57	235	25	24.44	2530	0.9	CHO62	90B5/B14	90L4
	69	195	20	20.25	2380	1.0			
	95	141	15	14.67	2130	1.4			
	110	122	12.5	12.67	2030	1.4			
	133	101	10	10.50	1910	1.7			
	184	73	7.5	7.60	1710	2.1			
	47	286	60	59.44	3690	1.2	CHO72	90B5/B14	90S2
	58	232	50	48.18	3440	1.5			
70	193	40	40.13	3240	1.8				
93	145	30	30.24	2950	2.4				



GETRIEBEAUSWAHLTABELLEN

P_{1n}	n_2	M_{2n}	i	i	F_{r2}	f_s			
[Kw]	[r/min]	[Nm]	nominal	actual	[N]				
1.5	35	386	40	40.13	4080	0.9	CHO72	90B5/B14	90L4
	46	291	30	30.24	3720	1.2			
	56	242	25	25.19	3500	1.4			
	71	191	20	19.84	3230	1.8			
	93	145	15	15.09	2950	2.4			
	112	120	12.5	12.49	2770	2.8			
	142	95	10	9.84	2550	3.3			
	47	284	60	59.04	4670	1.6	CHO82	90B5/B14	90S2
	58	232	50	48.18	4360	2.2			
	29.1	463	50	48.18	5500	1.1	CHO82	90B5/B14	90L4
35	386	40	40.13	5170	1.3				
46	291	30	30.24	4710	1.7				
56	242	25	25.19	4430	2.1				
71	191	20	19.84	4090	2.6				
2.2	139	143	20	20.21	1650	0.9	CHO52	90B5/B14	90L2
	188	105	15	14.92	1490	1.2			
	225	88	12.5	12.47	1400	1.4			
	267	74	10	10.47	1320	1.5			
	362	55	7.5	7.73	1200	1.8			
	92	214	30	30.31	2160	0.9	CHO62	90B5/B14	90L2
	115	172	25	24.44	2010	1.2			
	138	143	20	20.25	1890	1.4			
	191	103	15	14.67	1690	1.8			
	221	89	12.5	12.67	1610	1.8			
	267	74	10	10.50	1510	1.8			
	368	54	7.5	7.60	1360	1.9			
	58	340	50	48.18	3440	1.0	CHO72	90B5/B14	90L2
	70	283	40	40.13	3240	1.2			
	93	213	30	30.24	2950	1.6			
	111	178	25	25.19	2770	2.0			
	56	355	25	25.19	3500	1.0	CHO72	100B5/B14	100A4
	71	280	20	19.84	3230	1.3			
	93	213	15	15.09	2950	1.6			
	112	176	12.5	12.49	2770	1.9			
	142	139	10	9.84	2550	2.3			
	187	106	7.5	7.48	2330	2.9			
	47	416	60	59.04	4670	1.1	CHO82	90B5/B14	90L2
	58	340	50	48.18	4360	1.5			
	70	283	40	40.13	4110	1.8			
	93	213	30	30.24	3740	2.3			
	35	566	40	40.13	5170	0.9	CHO82	100B5/B14	100A4
	46	427	30	30.24	4710	1.2			
	56	355	25	25.19	4430	1.4			
	71	280	20	19.84	4090	1.8			
93	213	15	15.09	3730	2.3				

2D - und 3D-Zeichnungen auf der Website : www.chiaravalli.com
Menge, Verfügbarkeit und Preise bei ZM Antriebstechnik anfragen



GETRIEBEAUSWAHLTABELLEN

P_{1n} [Kw]	n_2 [r/min]	M_{2n} [Nm]	i nominal	i actual	F_{r2} [N]	f_s			
2.2	112	176	12.5	12.49	3510	2.6	CHO82	100B5/B14	100A4
3	70	386	40	40.13	3240	0.9	CHO72	100B5/B14	100L2
	93	291	30	30.24	2950	1.2			
	111	242	25	25.19	2770	1.4			
	141	191	20	19.84	2560	1.8			
	186	145	15	15.09	2340	2.4			
	224	120	12.5	12.49	2190	2.9			
	285	95	10	9.84	2030	3.7			
	374	72	7.5	7.48	1850	3.9			
	93	290	15	15.09	2950	1.2	CHO72	100B5/B14	100LB4
	112	240	12.5	12.49	2770	1.5			
	142	189	10	9.84	2550	1.8			
	187	144	7.5	7.48	2330	1.9			
	47	568	60	59.04	4670	0.8	CHO82	100B5/B14	100L2
	58	463	50	48.18	4360	1.1			
	70	386	40	40.13	4110	1.3			
	93	291	30	30.24	3740	1.7			
	111	242	25	25.19	3520	2.1			
	141	191	20	19.84	3250	2.6			
	56	485	25	25.19	4430	1.0	CHO82	100B5/B14	100LB4
	71	382	20	19.84	4090	1.3			
	93	290	15	15.09	3730	1.7			
	112	240	12.5	12.49	3510	1.9			
	142	189	10	9.84	3240	2.4			
4	111	323	25	25.19	2770	1.1	CHO72	112B5/B14	100LB2
	141	254	20	19.84	2560	1.4			
	186	194	15	15.09	2340	1.8			
	224	160	12.5	12.49	2190	2.2			
	285	126	10	9.84	2030	2.5			
	374	96	7.5	7.48	1850	2.9			
	112	320	12.5	12.49	2770	1.0	CHO72	112B5/B14	112M4
	142	252	10	9.84	2550	1.3			
	187	192	7.5	7.48	2330	1.5			
	70	515	40	40.13	4110	1.0	CHO82	112B5/B14	100LB2
	93	388	30	30.24	3740	1.3			
	111	323	25	25.19	3520	2.0			
	141	254	20	19.84	3250	2.0			
	186	194	15	15.09	2960	2.6			
	71	509	20	19.84	4090	1.0	CHO82	112B5/B14	112M4
	93	387	15	15.09	3730	1.3			
	112	320	12.5	12.49	3510	1.4			
	142	252	10	9.84	3240	1.8			
	187	192	7.5	7.48	2950	2.3			



CHO 52

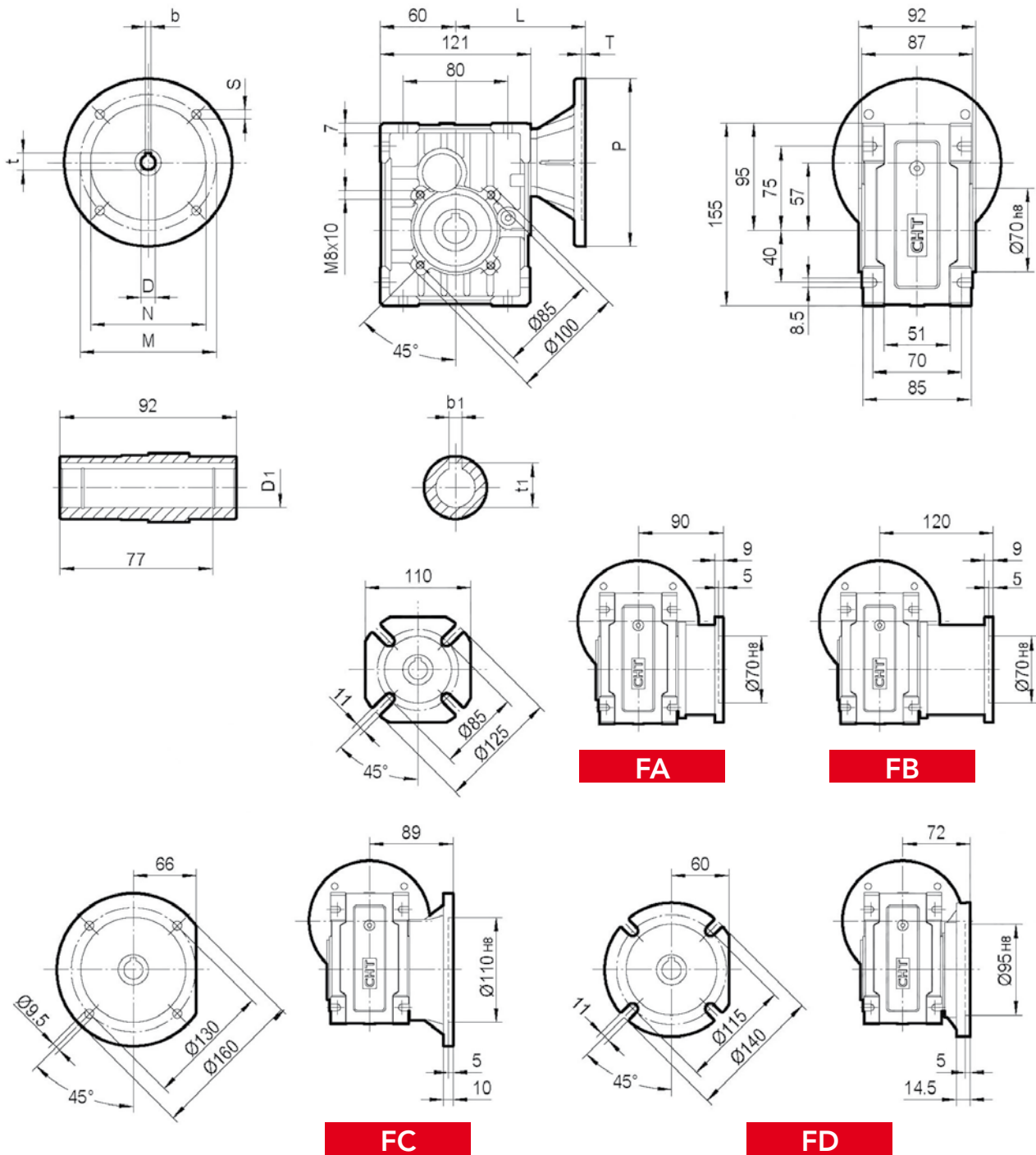

FA

FB

FC

FD

IEC	DE8	b	t	P	M	N	S	T	L	D1 H8	b1	t1
63B5	11	4	12.8	140	115	95	9	4	106	20*	6*	22.8*
71B5	14	5	16.3	160	130	110	9	4	113	25	8	28.3
71B14	14	5	16.3	105	85	70	7	4	113			
80B5	19	6	21.8	200	165	130	11	4	133			
80B14	19	6	21.8	120	100	80	7	4	133	* nur auf Anfrage		
90B14	24	8	27.3	140	115	95	9	4	133			

Gewicht 3.5 Kg ohne Motor



CHO 53

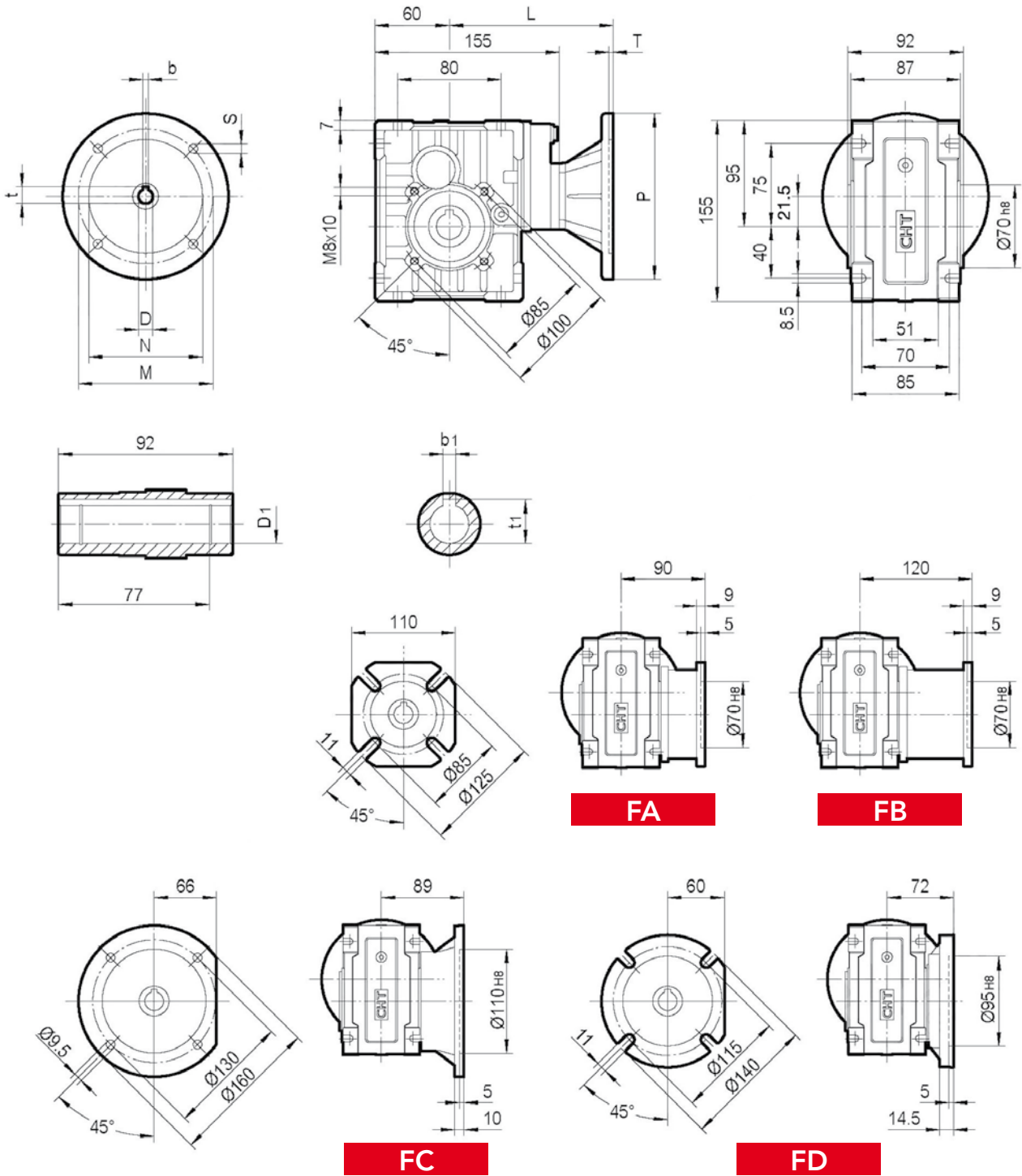

IEC	DE8	b	t	P	M	N	S	T	L	D1_H8	b1	t1
63B5	11	4	12.8	140	115	95	9	4	140	20*	6*	22.8*
71B5	14	5	16.3	160	130	110	9	4	147	25	8	28.3
71B14	14	5	16.3	105	85	70	7	4	147			
80B5	19	6	21.8	200	165	130	11	4	167			
80B14	19	6	21.8	120	100	80	7	4	167	* nur auf Anfrage		
90B14	24	8	27.3	140	115	95	9	4	167			

Gewicht 3.5 Kg ohne Motor



CHO 62

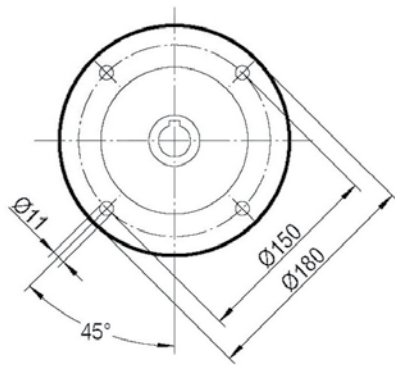
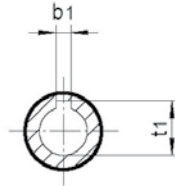
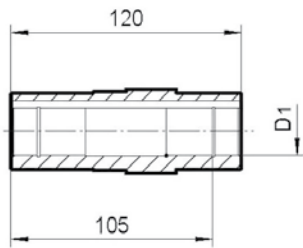
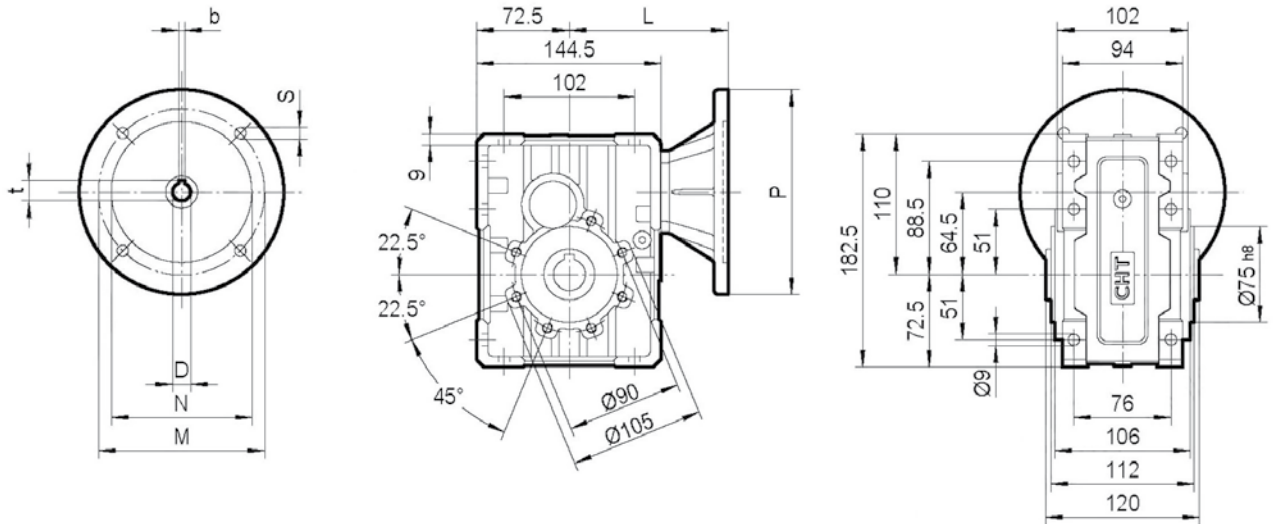

FA

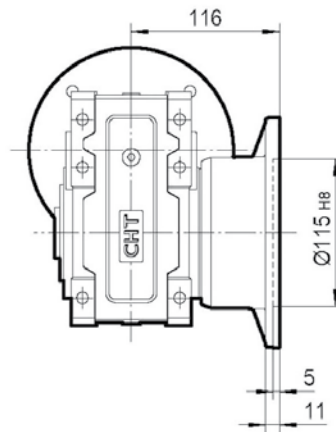

FB

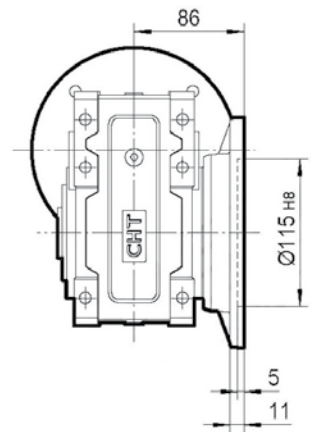

IEC	DE8	b	t	P	M	N	S	T	L	D1 H8	b1	t1
63B5	11	4	12.8	140	115	95	9	4	117	25	8	28.3
71B5	14	5	16.3	160	130	110	9	4	124			
71B14	14	5	16.3	105	85	70	7	4	124			
80B5	19	6	21.8	200	165	130	11	4	144			
80B14	19	6	21.8	120	100	80	7	4	144			
90B5	24	8	27.3	200	165	130	11	4	144			
90B14	24	8	27.3	140	115	95	9	4	144			

Gewicht 6.5 Kg ohne Motor



CHO 63

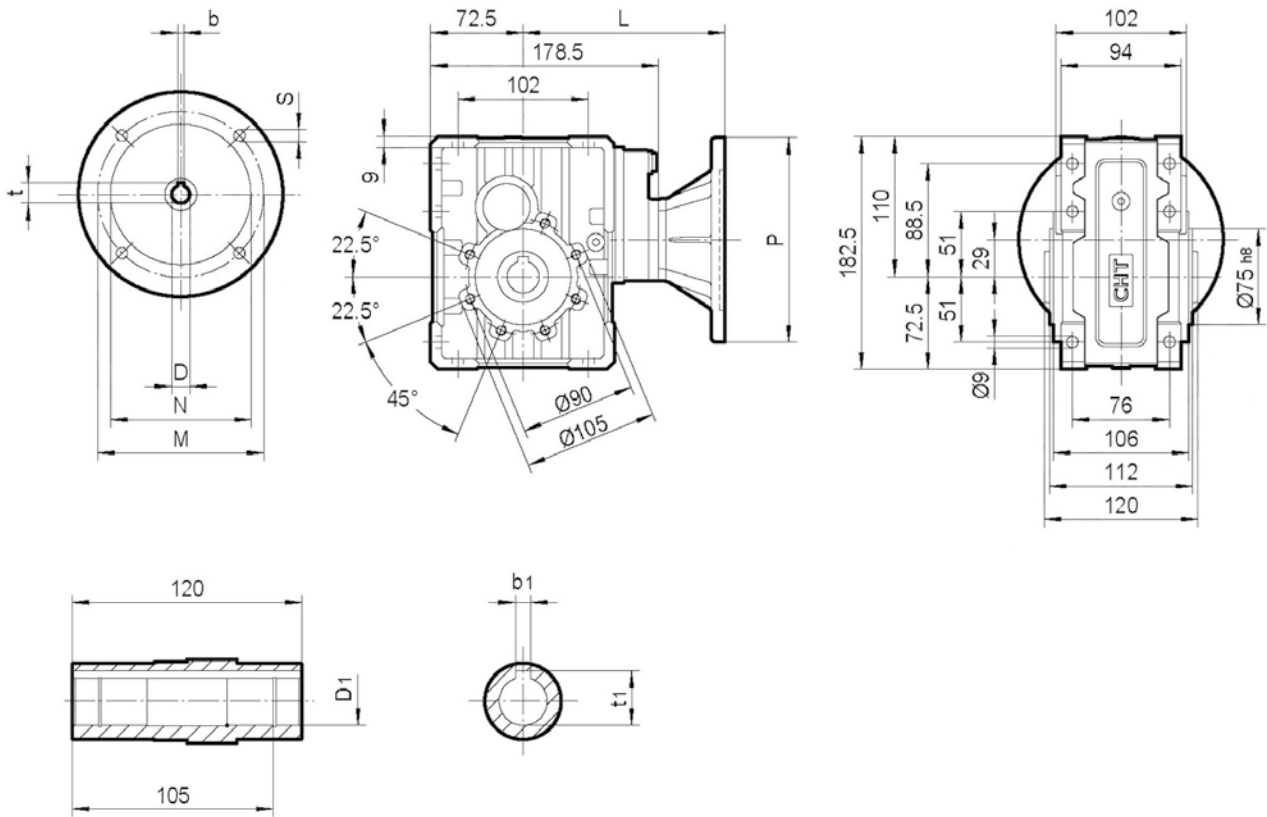

FA

FB

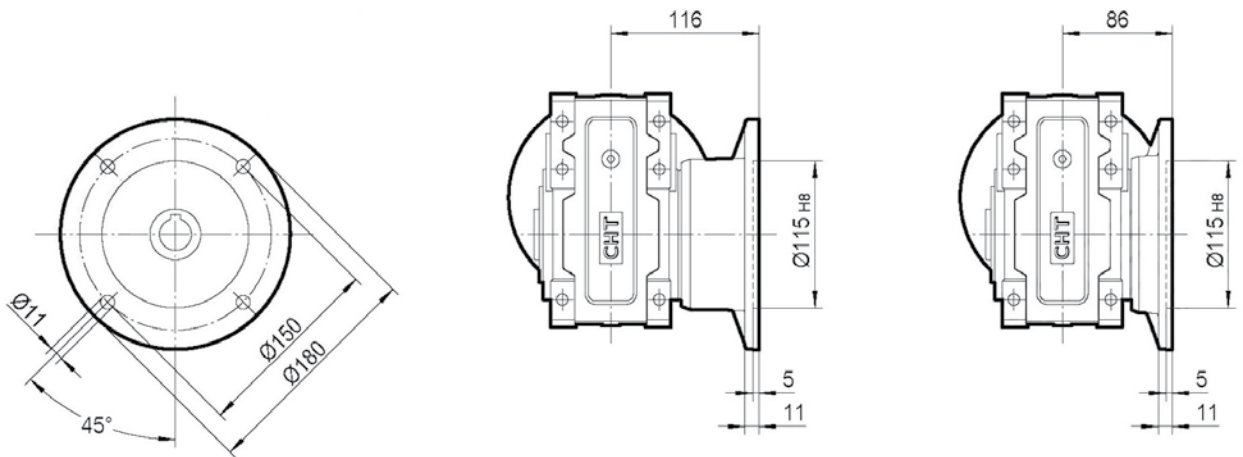

IEC	DE8	b	t	P	M	N	S	T	L	D1 HB	b1	t1
63B5	11	4	12.8	140	115	95	9	4	151	25	8	28.3
71B5	14	5	16.3	160	130	110	9	4	158			
71B14	14	5	16.3	105	85	70	7	4	158			
80B5	19	6	21.8	200	165	130	11	4	178			
80B14	19	6	21.8	120	100	80	7	4	178			
90B5	24	8	27.3	200	165	130	11	4	178			
90B14	24	8	27.3	140	115	95	9	4	178			

Gewicht 6.5 Kg ohne Motor



CHO 72

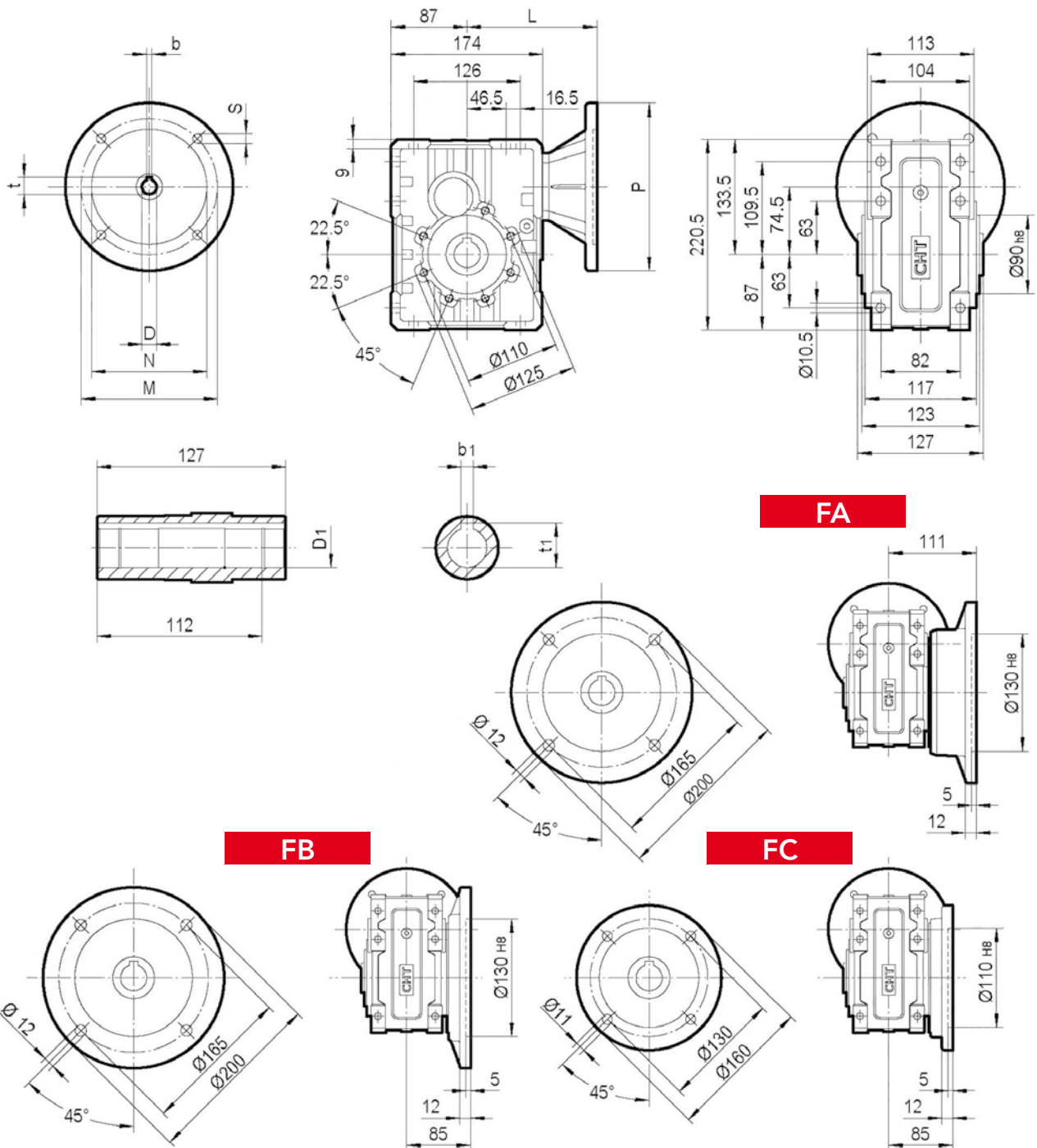

112

IEC	DE8	b	t	P	M	N	S	T	L	D1 H8	b1	t1
63B5	11	4	12.8	140	115	95	9	4	139	28*	8*	31.3*
71B5	14	5	16.3	160	130	110	9	4	146	30	8	33.3
80B5	19	6	21.8	200	165	130	11	4	166			
80B14	19	6	21.8	120	100	80	7	4	166			
90B5	24	8	27.3	200	165	130	11	4	166			
90B14	24	8	27.3	140	115	95	9	4	166			
100/112B5	28	8	31.3	250	215	180	13.5	4.5	176	* nur auf Anfrage		
100/112B14	28	8	31.3	160	130	110	9	4.5	176			

Gewicht 9.5 Kg ohne Motor



CHO 73

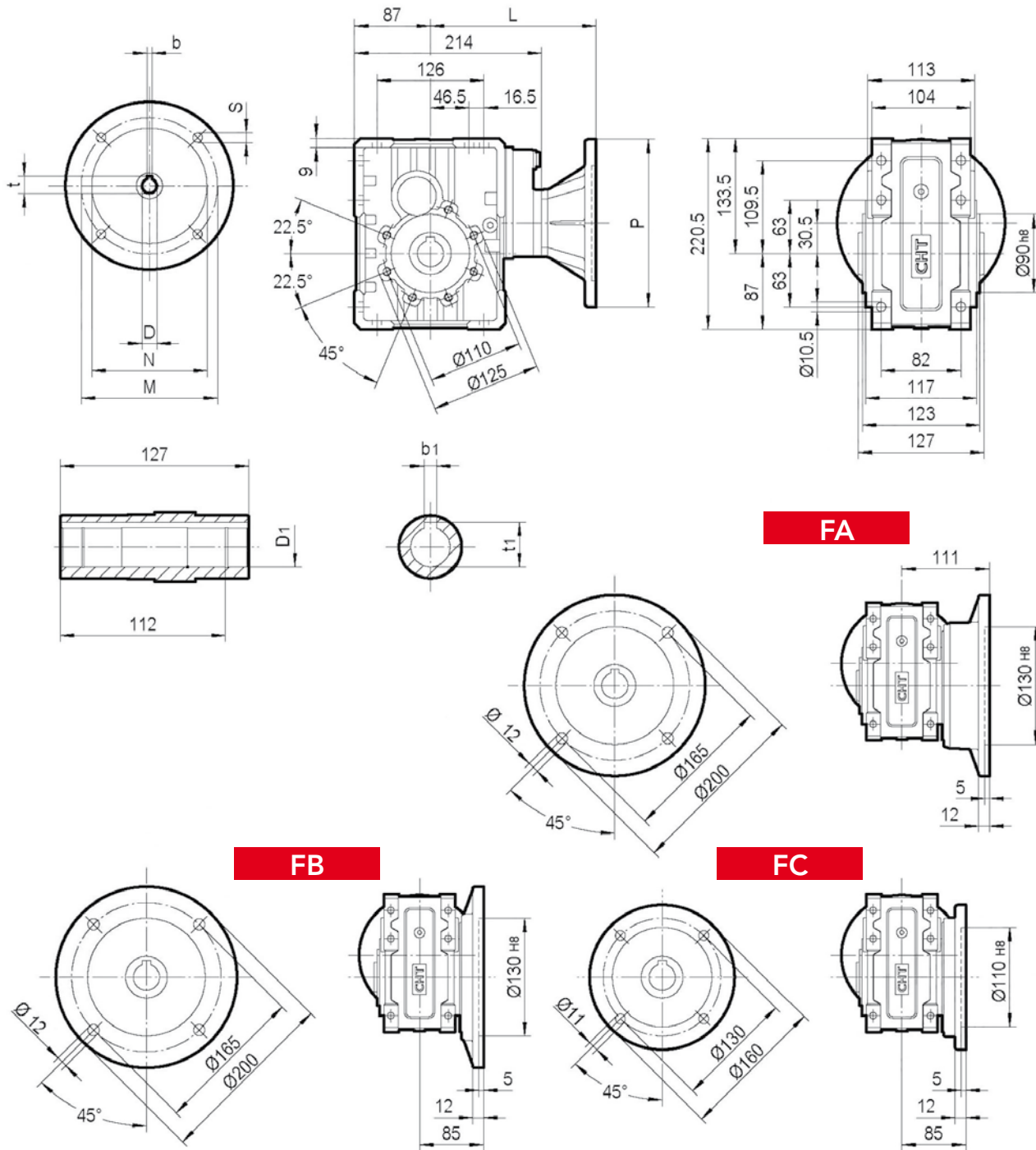

IEC	DE8	b	t	P	M	N	S	T	L	D1 H8	b1	t1
63B5	11	4	12.8	140	115	95	9	4	179	28*	8*	31.3*
71B5	14	5	16.3	160	130	110	9	4	186	30	8	33.3
80B5	19	6	21.8	200	165	130	11	4	206			
80B14	19	6	21.8	120	100	80	7	4	206			
90B5	24	8	27.3	200	165	130	11	4	206			
90B14	24	8	27.3	140	115	95	9	4	206			
100/112B5	28	8	31.3	250	215	180	13.5	4.5	216	* nur auf Anfrage		
100/112B14	28	8	31.3	160	130	110	9	4.5	216			

Gewicht 9.5 Kg ohne Motor



CHO 82

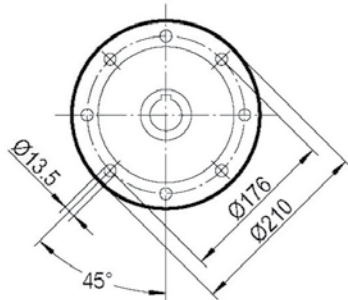
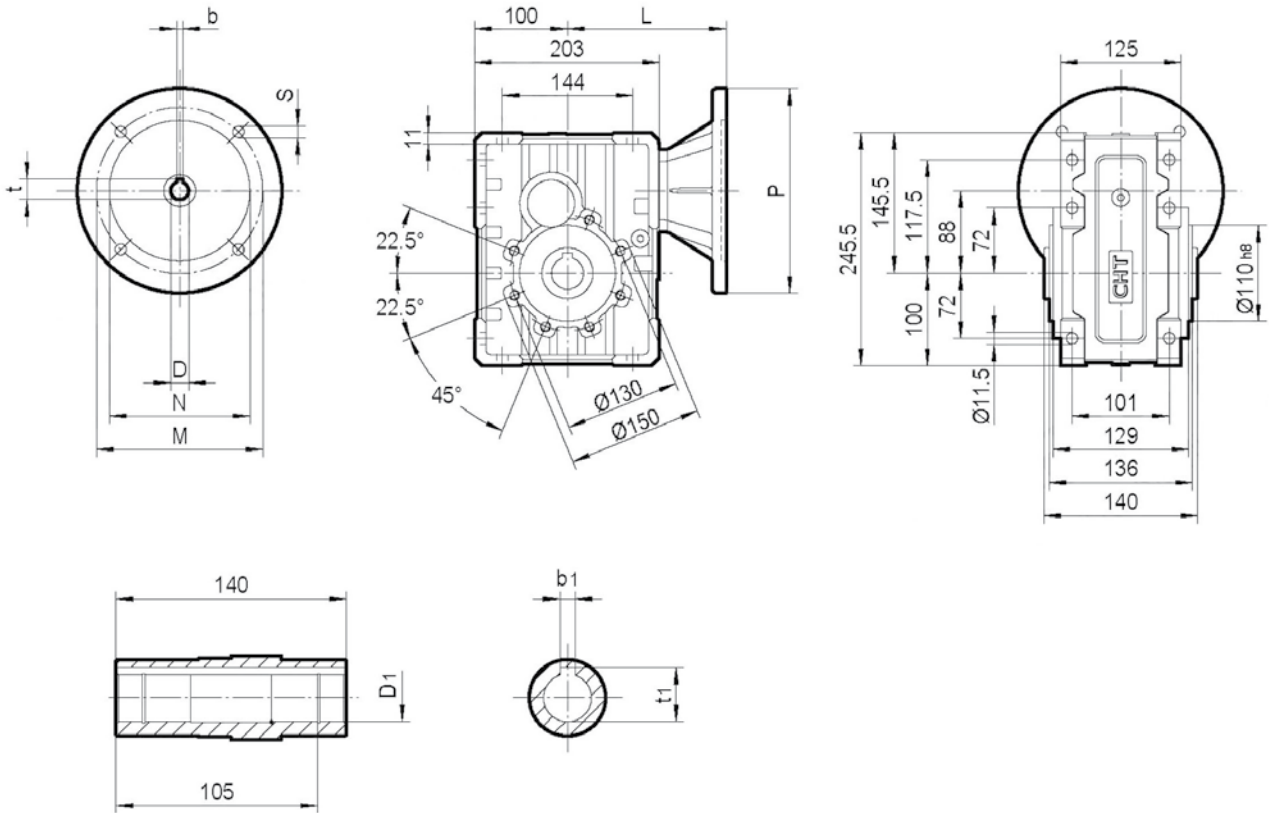

FA

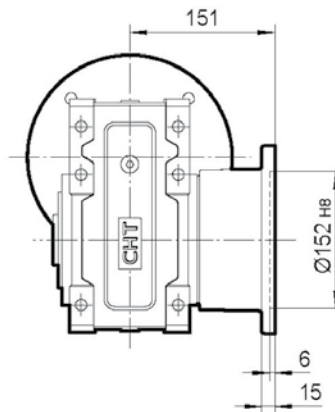

FB

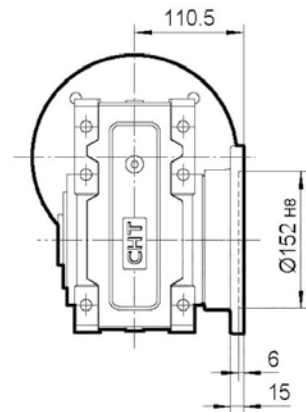

IEC	DE8	b	t	P	M	N	S	T	L	D1 H8	b1	t1
63B5	11	4	12.8	140	115	95	9	4	155	35	10	38.3
71B5	14	5	16.3	160	130	110	9	4	162			
80B5	19	6	21.8	200	165	130	11	4	182			
80B14	19	6	21.8	120	100	80	7	4	182			
90B5	24	8	27.3	200	165	130	11	4	182			
90B14	24	8	27.3	140	115	95	9	4	182			
100/112B5	28	8	31.3	250	215	180	13.5	4.5	192			
100/112B14	28	8	31.3	160	130	110	9	4.5	192			

Gewicht 13.5 Kg ohne Motor



CHO 83

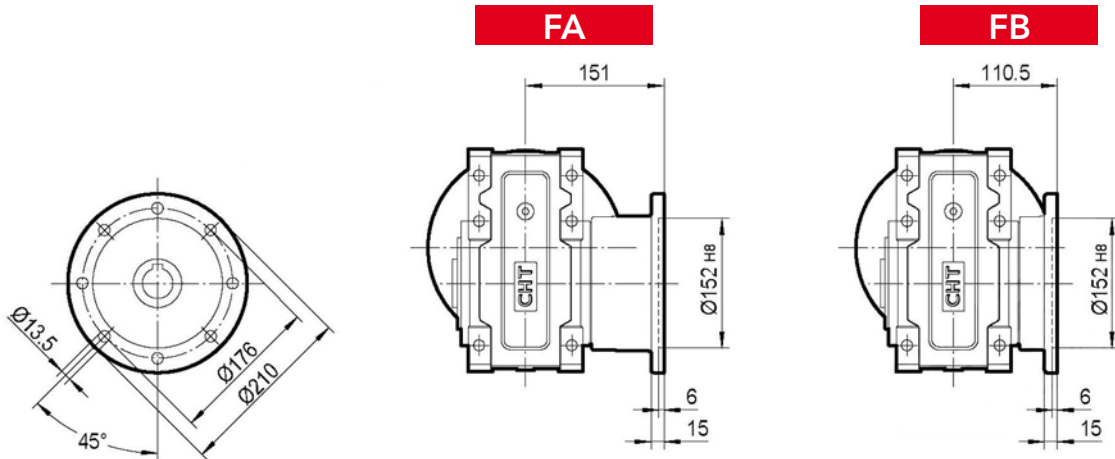
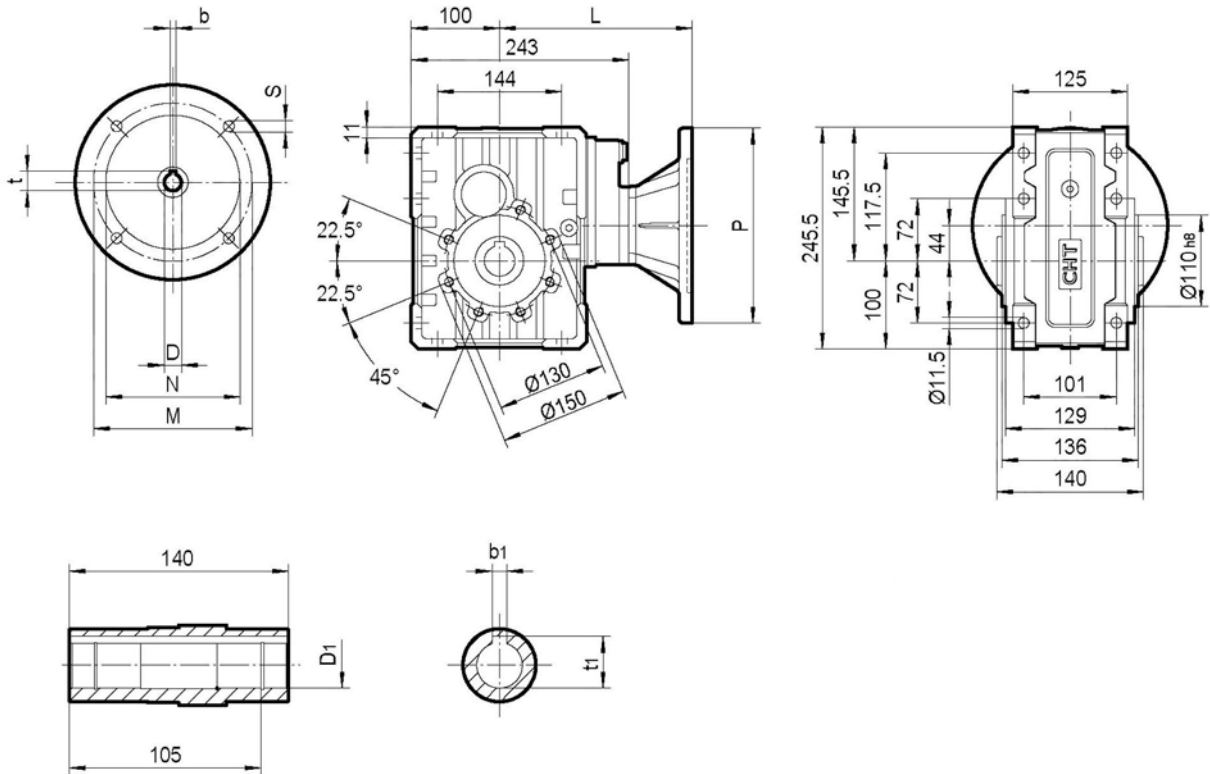

IEC	DE8	b	t	P	M	N	S	T	L	D1 H8	b1	t1
63B5	11	4	12.8	140	115	95	9	4	195	35	10	38.3
71B5	14	5	16.3	160	130	110	9	4	202			
80B5	19	6	21.8	200	165	130	11	4	222			
80B14	19	6	21.8	120	100	80	7	4	222			
90B5	24	8	27.3	200	165	130	11	4	222			
90B14	24	8	27.3	140	115	95	9	4	222			
100/112B5	28	8	31.3	250	215	180	13.5	4.5	232			
100/112B14	28	8	31.3	160	130	110	9	4.5	232			

Gewicht 13.5 Kg ohne Motor



ZUBEHÖR

EINBAULAGEN

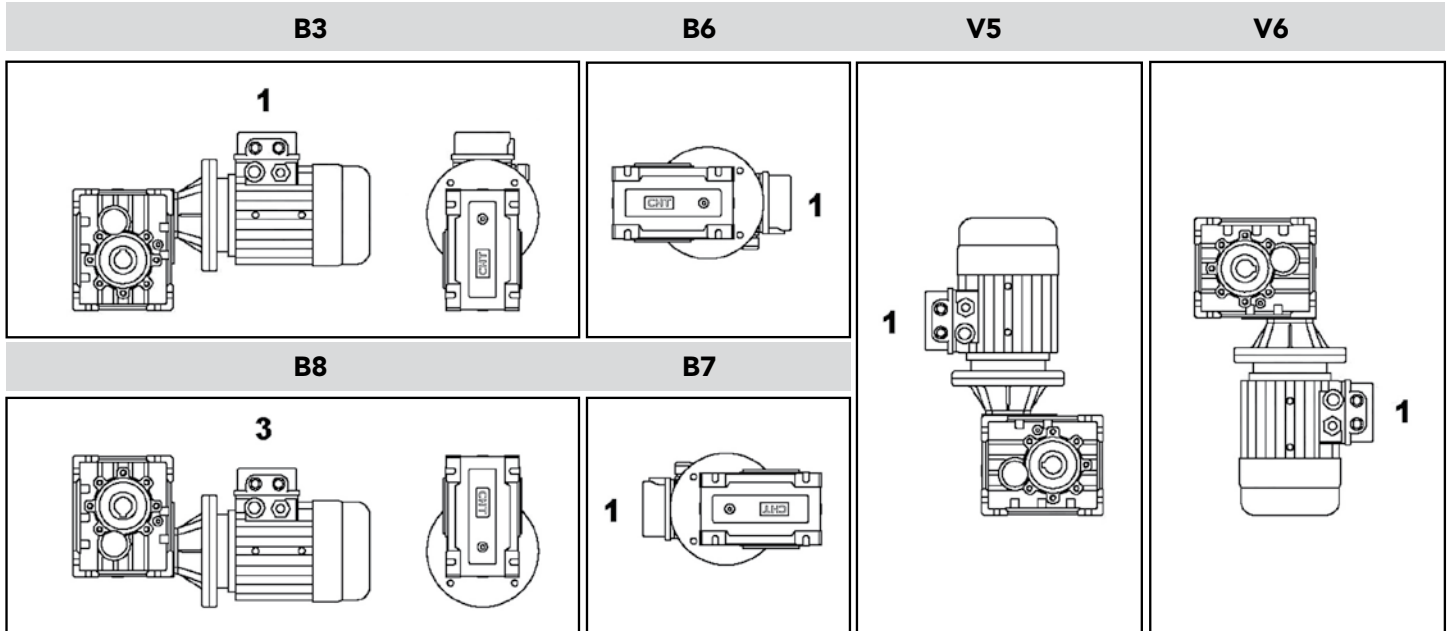

SCHUTZDECKEL

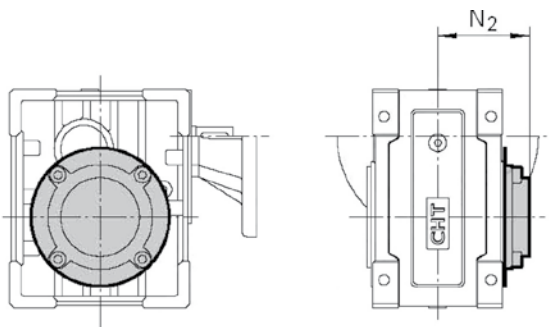

TYPE	N ₂
CHO 52/53	59
CHO 62/63	70
CHO 72/73	85.5
CHO 82/83	93.5



ZUBEHÖR

ABTRIEBSWELLE

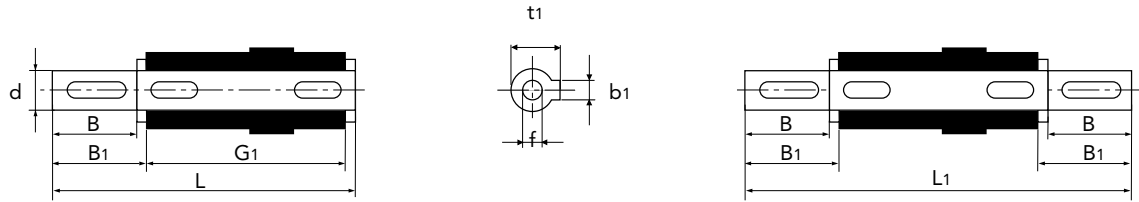

SS

DS

TYPE	d_{h6}	B	B ₁	G ₁	L	L ₁	f	b ₁	t ₁
CHO 52/53	25	50	53.5	92	153	199	M10	8	28
CHO 62/63	25	60	65	120	192	246.4	M8	8	28
CHO 72/73-28	28	60	65	127	199	255	M8	8	31
CHO 72/73-30	30	60	65	127	199	255	M10	8	33
CHO 82/83	35	60	65	140	214	268	M12	10	38



DREHMOMENTENSTÜTZE

TYPE	l	A	B	Ø P	Ø C	Ø d	H	øE	S
CHO 52/53	100	50	168	70	85	9	14	10	4
CHO 62/63	150	52.5	232.5	75	90	9	20	10	6
CHO 72/73	200	62.5	300	90	110	9	25	20	6
CHO 82/83	200	75	312,5	110	130	11	25	20	6

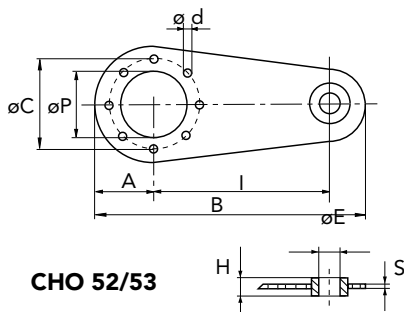

CHO 52/53

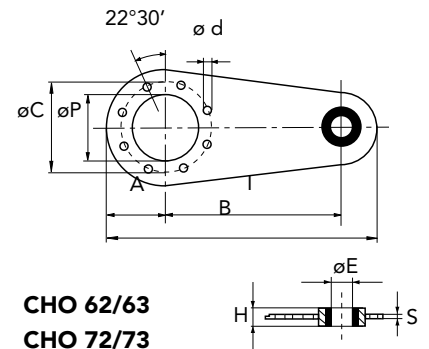
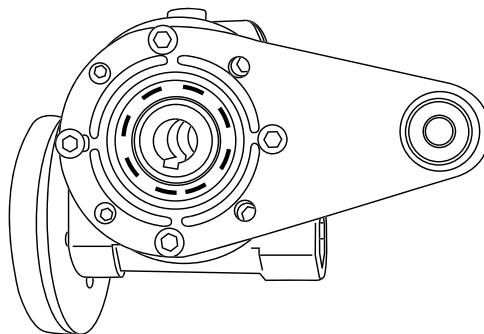

CHO 62/63
CHO 72/73
CHO 82/83

Die Drehmomentstütze ist mit einer Elastomere Buchse ausgestattet.



POSITIONSSCHEMA AUSGANG

FA1, FB1, FC1, FD1, FE1

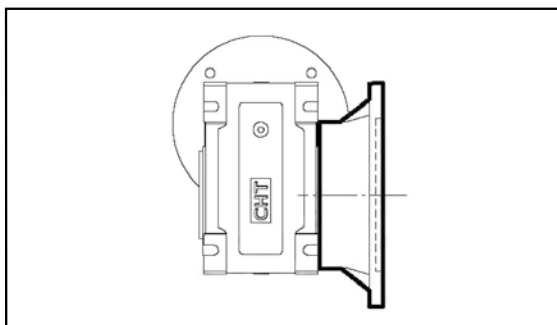

FA2, FB2, FC2, FD2, FE2

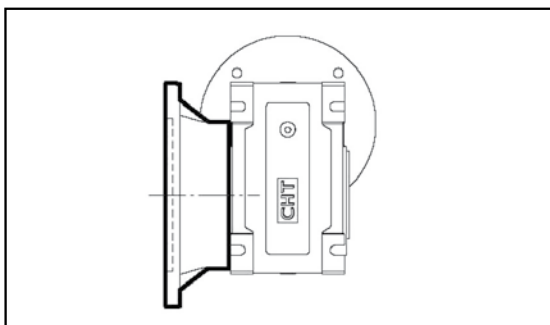

Wenn nicht anders angegeben,
wird das Getriebe mit Flansch
für Pos F1 geliefert
F1 bezogen auf Einbaulage B3 .

SS1

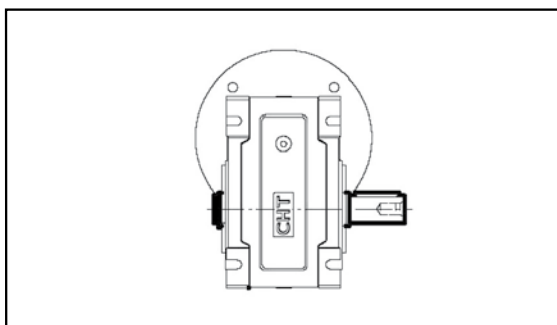

SS2

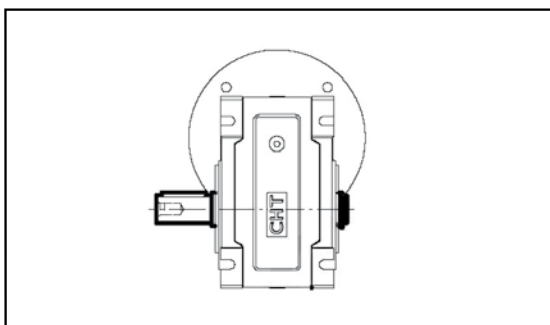

POSITIONSSCHEMA KLEMMKASTEN

1 Standard

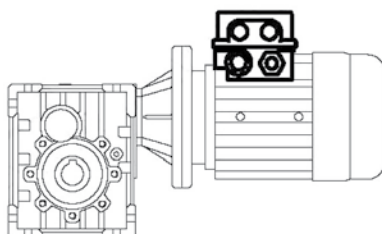
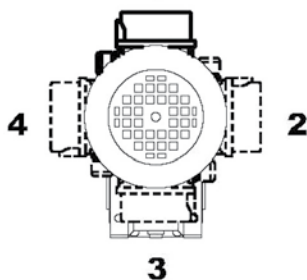

1 Standard

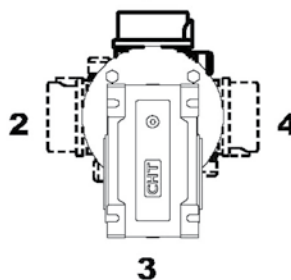

Im Bestellfall geben Sie die
Position des Klemmkasten an,
wie in der Abbildung
dargestellt.



EXPLOSIONZEICHNUNG UND ERSATZTEILLISTE

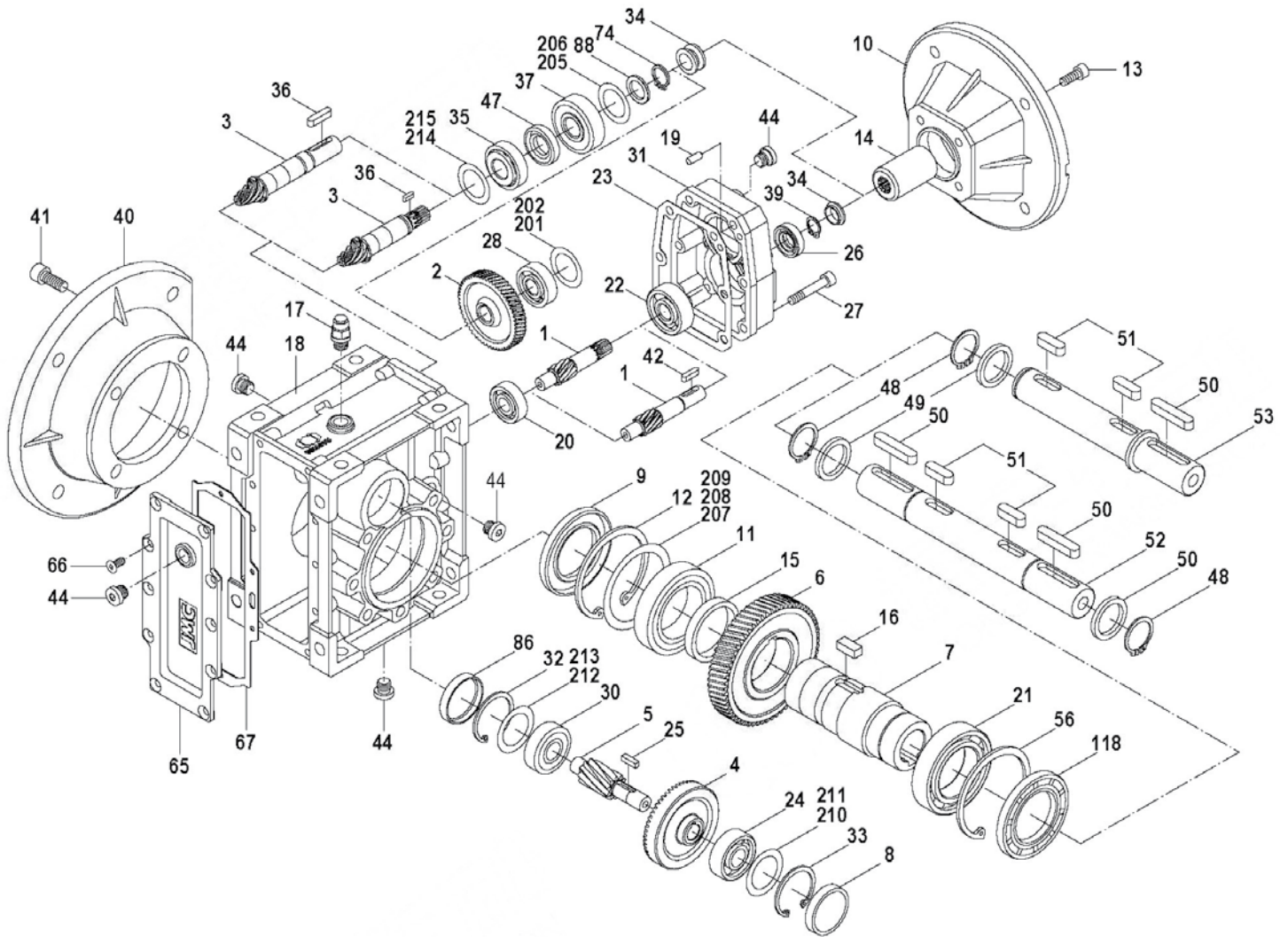

1	RITZEL	39	SEEGERRING
2	ZAHNRAD	40	ABTRIEBSFLANSCH
3	RITZELWELLE	41	INNENSECHSKANTSCHRAUBE
4	ZAHNRAD	42	PASSFEDER
5	RITZELWELLE	44	VERSCHLUSSSCHRAUBE
6	ZAHNRAD	47	WELLENDICHTRING
7	HOHLWELLE	48	SEEGERRING
8	VERSCHLUSSKAPPE	49	DICHTUNG
9	WELLENDICHTRING	50	PASSFEDER
10	EINGANGSFLANSCH	51	PASSFEDER
11	LAGER	52	DOPPEL ABTRIEBSWELLE
12	SEEGERRING	53	DOPPEL ABTRIEBSWELLE
13	INNENSECHSKANTSCHRAUBE	56	SEEGERRING
14	EINGANGSWELLE	65	GETRIEBEDECKEL
15	SPACER	66	INBUSSCHRAUBE
16	PASSFEDER	67	GUMMIDICHTUNG
17	LÜFTERVENTIL	74	SEEGERRING
18	GETRIEBEGEHÄUSE	86	VERSCHLUSSKAPPE
19	STIFTE	88	UNTERLEGSCHIBE
20	LAGER	118	WELLENDICHTRING
21	LAGER	201	DISTANZRING
22	LAGER	202	DISTANZRING
23	GEHÄUSEDICHTUNG	205	DISTANZRING
24	BEARING	206	DISTANZRING
25	PASSFEDER	207	DISTANZRING
26	WELLENDICHTRING	208	DISTANZRING
27	INNENSECHSKANTSCHRAUBE	209	DISTANZRING
28	LAGER	210	DISTANZRING
30	LAGER	211	DISTANZRING
31	3 STUFE GETRIEBEGEHÄUSE	212	DISTANZRING
32	SEEGERRING	213	DISTANZRING
33	SEEGERRING	214	DISTANZRING
34	RUBBER RING	215	DISTANZRING
35	LAGER	216	DISTANZRING
36	PASSFEDER	217	DISTANZRING
37	LAGER		



INSTALLATION

- Die Daten auf dem Typenschild müssen dem bestellten Getriebe entsprechen.
- Der Ölstand muss der Menge entsprechen, die für die Montageposition vorgesehen wird. (siehe Katalog).
- Alle anderen Geriebe sind mit Synthetiköl für Dauerschmierung versehen, die für jede Einbaulage ausreichend ist.
- Das Getriebe muss auf einer ebenen Fläche befestigt werden, die ausreichend steif ist, um jegliche Vibrationen zu vermeiden.
- Das Getriebe und die Maschinenwelle müssen perfekt ausgerichtet werden, so dass eine Überlastung oder Blockade der Maschine verhindert wird.
Im anderen Fall muss der Kunde eine Begrenzungseinrichtung installieren.
zb. Gelenkwelle, Überlastkupplung usw.
- Vor Montage von Ritzeln, Gelenke, Riemscheiben usw. müssen alle Teile gereinigt werden, während der Montage müssen Stöße und Schläge vermieden werden, da sie die Lager und andere Bauteile beschädigen könnten.
- im Fall einer Motormontage durch den Kunden, muss er prüfen, ob die Flansch- und Wellentoleranzen zu einer "normalen" Klasse entsprechen; unsere Motoren erfüllen diese Anforderung.
- Überprüfen Sie, ob die Befestigungsschrauben und Zubehör richtig angezogen sind.
- Treffen Sie geeignete Maßnahmen, um gegen aggressive Witterungseinflüssen zu schützen.
- alle drehenden Teile sind zum Schutz des Betreibers abzudecken.
- Bei Lackieren des Antriebs sind die Dichtungen und die bearbeiteten Flächen abzukleben
- Alle Getriebe sind in RAL 9022 lackiert.

BETRIEB UND INBETRIEBNAHME

- die beste Leistung zu erhalten, müssen die Getriebe erst nach und nach eingefahren werden, indem die Leistung in den ersten Betriebsstunden langsam erhöht wird, in dieser Phase in der die Temperaturerhöhung als normal betrachtet wird.
- Im Falle eines fehlerhaften Betriebs, Geräusche, Ölverlust, usw. sofort das Getriebe stoppen

und wenn möglich die Ursache entfernen. Alternativ das Getriebe zur Überprüfung zurück senden

INSTANDHALTUNG

- Die Kegelstirnradgetriebe sind mit Mineralöl gefüllt, nicht mit synthetischem Öl mischen.
Überprüfen Sie regelmäßig den Ölstand.

WAREHOUSE STORAGE

- Bei Einlagerung von mehr als 3 Monate, sollten die Wellen und bearbeiteten Oberflächen geschützt mit Antioxidantien geschützt werden und die Dichtungen sollte eingeschmiert werden.

HANDLING

- Bei Montage muss darauf geachtet werden, nicht die Öldichtungen und die bearbeitenden Oberflächen zu beschädigen

ENTSORGUNG DER VERPACKUNG.

- Die Verpackung, in der unsere Getriebe geliefert werden, sind recyclingfähig.